

OPERATOR'S MANUAL FOR

Cosmos III

Digital



Veatch

Ophthalmic

Instruments

Contents

1. Uses and Characteristics of Device.....	3
2. Main Technical Indexes.....	3
3. Working Principle of Device.....	4
4. Description of the Device Structure.....	4
4.1 Main View.....	4
4.2 Drone and Ocular Dividing Plate	6
4.3 Liquid Crystal Display Screen.....	7
5. Operation Instruction.....	8
5.1 Before Measurement.....	8
5.2 Measurement of Lens.....	10
5.3 Calibration of Lens.....	16
5.4 Function of Automatic Dormancy.....	16
5.5 Setting Grades of Measurement.....	17
6. Maintenance of Device.....	17
7. Troubleshooting.....	18

1 Uses and Characteristics of Device

This device is divided into two models, A and B, in which A is standard model and B is strengthened model with prism compensator.

Important Prompt

In the following description, all sections or content marked with “*” before them are specialized content of model B device.

Optic, machine and microelectronic integrated technologies are adopted in this device, where, yellow liquid crystal display is available to achieve stable and precise measuring result, proven to be an ideal device for having one’s eyesight tested for spectacles. This device is applicable to all level measurement testing departments, spectacles manufacturers, spectacles retail stores, hospital’s department of ophthalmology and optical elements factories for conducting measurement of spherical lens diopter of spectacles or lens, diopter of cylindrical lens, astigmatism axis angle of cylindrical lens, diopter of bifocal lens, prism degree and prism basal angle.

2 Main Technical Indexes

1. Range of measurement:
 - Spherical lens: -25D ~ +25D
 - Cylindrical lens: -9.99D ~ +9.99D
 - Space of readings: 0.01D, 0.06D, 0.12D, 0.25D
2. Astigmatism axis angle of cylindrical lens: 0 ~ 180° space of readings: 1°
3. Prism degree: Model A 0 ~ 5 Δ space of readings: 1 Δ;
* Model B 0 ~ 20 Δ space of readings: 1 Δ
4. Prism basal angle: 0 ~ 180° space of readings: 1°
180° ~ 360° space of readings: 5°
5. Range of ocular visibility adjustment: -5D ~ +5D
6. Size of measured lens: Φ16mm - Φ80mm
7. Overall dimensions: 320 mm (L) X 150 mm (W) X 450 mm (H)
8. Weight: Model A 4,9kg
* Model B 5 kg
9. Lamp of illumination: Φ5 super-lighting LED
10. Voltage: DC 6V/300mA
11. Power: 1.5W
12. Temperature: -10° C ~ +50° C (in operation)
-20° C ~ +60° C (in storage/during transport)
13. Humidity: 30 ~ 75% (in operation)
10 ~ 85%(in storage/during transport)

3 Working Principle of Device

Fig. 1 Drawing of Optical Principle for Model A

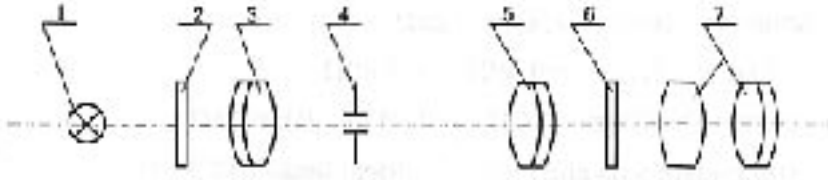
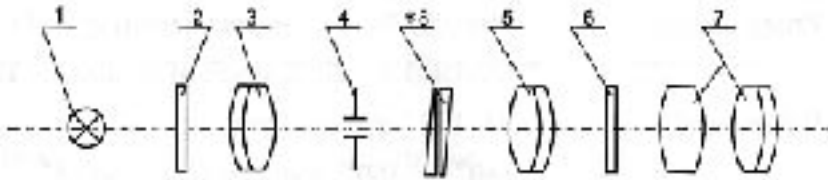

Fig. 2 Drawing of Optical Principle for Model B



- | | | |
|-----------------|-------------------------|----------------------------|
| 1. Light source | 2. Mark Dividing Plate | 3. Measurement Objective |
| 4. Diaphragm | 5. Telescopic Objective | 6. Eyepiece Dividing Plate |
| 7. Eyepiece Set | *8. Prism Compensator | |

This device consists of a coaxial optical system. Light sent forth from 1-Light Source (LED) lights up 2-Mark Dividing Plate. After passing through 3-Measurement Objective and 5-Telescopic Objective, 2-Mark Dividing Plate is imaged at position of 6-Eyepiece Dividing Plate. At this time, through 7-Eyepiece Set, the distinct reticule images of 2-Mark Dividing Plate and 6-Eyepiece Dividing Plate can be seen. During operation, put spectacle lens at the place of 4-Diaphragm (measurement bearing scat), and turn diopter measuring hand-wheel and astigmatism turning hand-wheel so that distinct image of 2-Mark Dividing Plate is obtained. Now, the number showing on the liquid crystal display screen is just the diopter value of this lens.

4 Description of the Device Structure

4.1 Main View (Fig3)



Fig. 3

1. Eyepiece

Eyepiece part is a screw type focusing unit with focusing range of $\pm 5D$, adaptable to different eye-sights of human eyes.

*2. Prism Compensator

It is used to measure prism lens with prism degree bigger than 5Δ .

3. Lens Pressing Mechanism

3 plastic pressing feet equipped with spring are used to press lens, able to stably press lens with any shape of surface, with no damage to lens surface.

4. Measurement Bearing Seal

It can hold lens with any shape of surface with no damage to lens surface.

5. Astigmatism Turning Hand-Wheel

It is used to measure and locate astigmatism axis angle of cylindrical lens and basal angle of prism lens.

6. Lens Pushing Board

When lens on the lens frame is conducted, lower part of lens frame (i.e. two lens rings) shall contact the lens pushing board.

7. Diameter Indication Measuring Scale

When lens pushing board contacts edge of lens, it is possible to read lens diameter.

8. Inclining Angle Adjusting Handle of Device

It is able to enable measurement operator to adjust inclining angle of the device easily, who can work with a comfortable posture. By rotating backwards the adjusting handle, measurement operator may tilt the device to a proper angle according to specific status of work table, then simply lock up the handle.

9. Power Supply Socket

10. Dot-Making Mechanism

This mechanism consists of 3 identical dot-making pens connected into a line, where, one in the middle is used to mark lens center, and connected line of marking dots of 3 pens is used to mark astigmatism axis angle of lens and basal angle of prism lens.

10. InkpadsBox

It is used to store inkpads or ink for print.

12. Lens Pushing Hand Lever

It is used to move lens pushing board back and forth.

13. Diopter Measuring Hand-wheel

4.2 Drone and Eyepiece Dividing Plate (Fig.4)

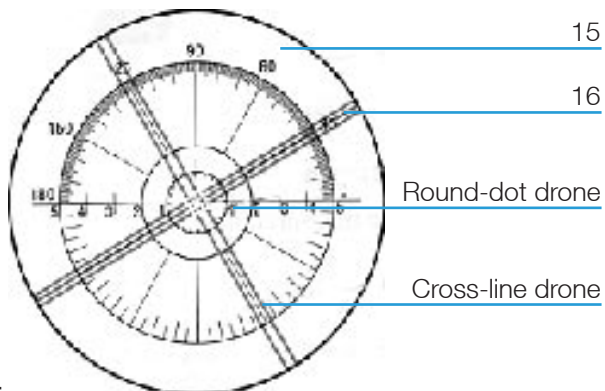

Fig. 4

15. Eyepiece Dividing Plate

Prism degree measuring scale and calibrated dial are marked on it. Prism degree is marked with space of 1Δ , where, integral prism degree is read directly on the measuring scale, and decimal prism degree is read by estimation from measuring scale. Calibrated dial $0 \sim 180^\circ$ is marked with space of 1° , and $180^\circ \sim 360^\circ$ with space of 5° .

16. Drone

Distinct image of mark dividing plate involves round-dot drone and cross-line drone.

4.3 Liquid Crystal Display Screen (Fig 5)

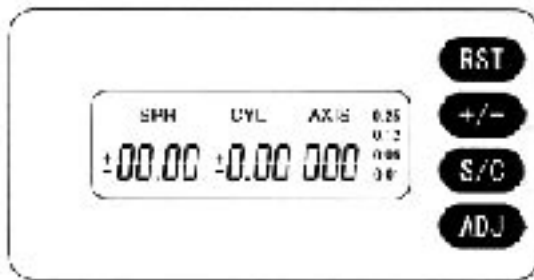

Fig. 5

14. Liquid Crystal Display Screen

It displays diopter value of the measured lens.

17. Reset Key RST

Pressing this key, it returns from other mode of measurement to the mode ready to Operate.

18. Measurement Switching Key +/-

When cylindrical lens is measured, pressing this key will realize switching of light intensity of cylindrical lens degree. Pressing it once more, it returns to the original state of display. It can be also used to set grade of measurement.

19. Measurement Switching Key S/C

Every time one presses this key, mode of measuring spherical lens or cylindrical lens will be changed. Start-up of this machine defaults mode of being ready to operate.

20. Adjustment Key ADJ

It is used to set grade of measurement.

5 Operation Instruction

5.1 Before Measurement

5.1.1 Preparation

- (1) Place the device on a working table with proper height to the extent that the adjusted inclined angle of the device will result in comfortable measurement for the operator.
- (2) Put power supply wire into socket, and the device comes into mode of being ready to operate (Fig.6). Turn diopter measuring hand-wheel. When digitals appear on the display screen, it indicates the device is put in mode of spherical lens measurement.

Important Prompt

Be sure to install measurement bearing seat correctly, otherwise it will result in imprecise measurement.

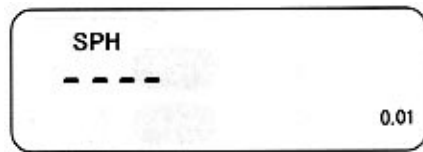

Fig. 6

- (3) Adjustment of ocular visibility. To obtain precise and reliable measuring result, ocular visibility shall be adjusted before measurement. The method is: observe black reticule digitals of eyepiece dividing plate 6 in eyepiece visual field. At the same time, the better way is to turn eyepiece cover in one way (one-way rotation can eliminate influence caused by action of eye adjustment) until the black reticule digitals become clearest.
- (4) Adjusting zero position of the device. Turn diopter measurement hand-wheel to focus drone to clearest state. At this time, the display degree of spherical lens is 0.00.
- * (5) If a prism compensator is provided, make sure that display of prism compensator is "0" before measurement. (Fig.7)

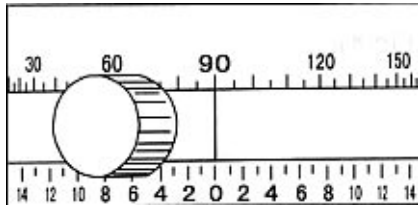

Fig. 7

Matters Needing Attention

- *(1) If diopter of testee's eye is deep or it has astigmatism, measurement shall be carried out only after he (she) wears spectacles for correcting visual acuity.
- *(2) To obtain most precise measuring result, the better way is to turn diopter measuring hand-wheel in one-way, with rotating direction of: - 25D → +25D.

5.1.2 Putting Lens in Position

- (1) Lens shall be placed on measurement bearing seat with concave facing downwards (Fig.8).

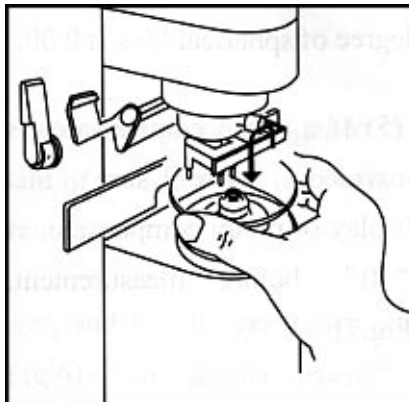

Fig. 8

- (2) Lift upwards the lens pressing mechanism, then lower it to press lens; when measurement is over, lift upwards the lens pressing mechanism again to the top end so that lens pressing mechanism is hung tightly and automatically.

- (3) When lens on the frame is measured, lower part of frame (i.e. two lens rings) should contact lens pushing board: turn lens pushing hand lever to push out the lens pushing board (Fig.9).

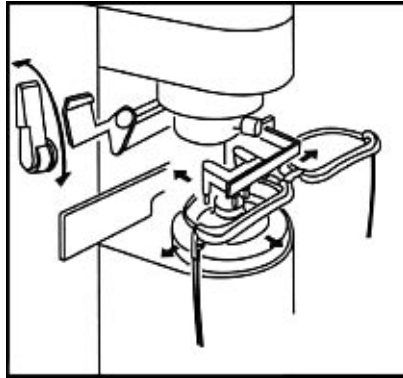

Fig. 9

5.2 Measurement of Lens

5.2.1 Measurement of Spherical Lens

- (1) Confirm the mode of cylindrical lens measurement, and turn diopter measuring hand-wheel to obtain distinct drone focus.

Prompt

If it is mode of cylindrical lens measurement, press measurement switching key S/C to switch it to mode of cylindrical lens measurement, the device will send out sound of “DuDu” simultaneously.

- (2) Lightly move lens so that drone is at center of eyepiece visual field. Then finely regulate diopter measuring hand wheel to obtain clearest focus of drone. At this time, the number on the liquid crystal display screen is just the spherical diopter of this lens (Fig. 10).

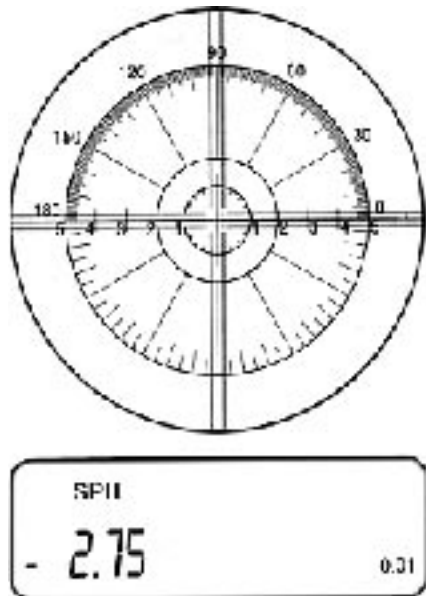

Fig. 10

5.2.2 Measurement of Cylindrical Lens

Cylindrical lens means astigmatism lens. Usually its external surface is spherical and interior surface is cylindrical or drum-shaped (i.e. interior astigmatism).

Refractive power on each section of its interior surface is different, in which, there are weakest refractive power and strongest refractive power on two mutually vertical sections.

When this device is used to measure such kind of lens, two long green lines and three long green lines of drone cannot be focused to be clear simultaneously.

Measurement shall be conducted according to following procedures:

- (1) Confirm the mode of spherical lens measurement.
- (2) Turn diopter measuring hand-wheel so that round dot drone is focused distinctly.
- (3) Lightly move lens to enable drone to be positioned at the center of eyepiece visual field.
- (4) Turn astigmatism turning hand-wheel so that two long green lines of round dot drone and cross-line drone are parallel.
- (5) Then finely regulate diopter measuring hand-wheel to obtain clearest focus of two long green lines of round dot drone and cross-line drone (Fig.11).

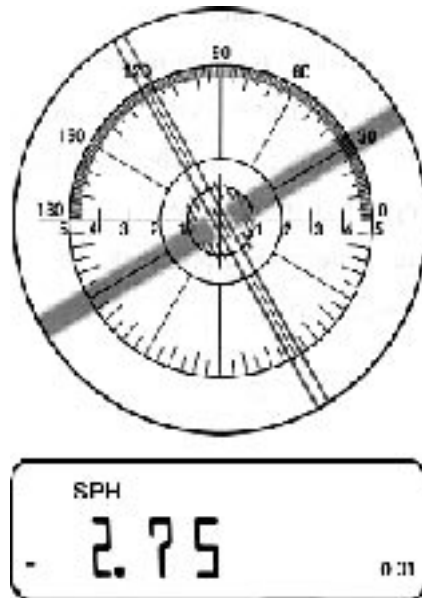

Fig. 11

- (6) By pressing measurement switching key S/C, the device sends out sound of “Du Du”, and it is switched to mode of cylindrical lens measurement (Fig.12).
- (7) Turn diopter measuring hand-wheel to obtain clearest focus of 3 long green lines of round dot drone and cross-line drone. At this time, spherical diopter (SPH), astigmatism degree (CYL) and astigmatism axis (AXIS) of this lens are shown on the liquid crystal display screen (Fig. 13).



Fig. 12

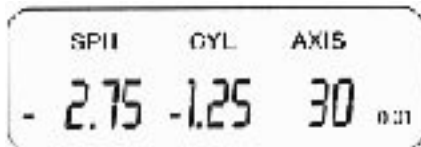

Fig. 13

Matters Needing Attention

If it is required to do light degree switching, press measurement switching key +/-, then the device sends out sound of “DuDu”, and switched value is shown whereat (Fig. 14).



Fig. 14

5.2.3 Measurement of Bifocal Lens

Function of measuring bifocal lens is to check how much near vision is added to distant vision.

- (1) According to measuring procedures of spherical lens and cylindrical lens in above stated Sections 5.2.1 and 5.2.2, measure distant vision of bifocal lens (i.e. diopter of big lens).
- (2) Press measurement switching key S/C to switch it to mode of cylindrical lens measurement.
- (3) Lightly move lens so that near vision part of bifocal lens (i.e. small lens) is placed on measurement bearing seat (Fig. 15), and drone is moved to center of eyepiece visual field.
- (4) Turn diopter measuring hand-wheel to obtain clearest focus of drone. At this time, diopter degree value of this bifocal lens is shown on liquid crystal display screen (Fig,16), where, SPH is spherical diopter, and CYL is additional diopter. At this time, AXIS data have no meaning, which can be ignored.

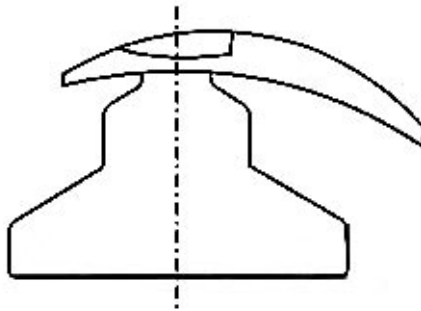

Fig. 15

Matters Needing Attention

*Lift up lens pressing mechanism a little when moving lens.



Fig. 16

Important Matters

If drone cannot be moved to center of eyepiece visual field because of prism function of lens, please use prism compensator to adjust drone to center of eyepiece visual field so as to achieve better result of focus.

5.2.4 Measurement of Prism Lens

Measuring prism degree of prism lens consists of 2 ranges: 0 ~ 5 degrees and 5 ~ 20 degrees of prism.

- (1) In the range of 0 ~ 5 degrees of prism, the value is read directly on the eyepiece dividing plate.
 - a. Place prism lens on the measurement bearing seat and turn diopter measuring hand-wheel to make drone focus distinct.
 - b. Turn astigmatism turning hand-wheel so that the middle one of 3 long green lines of cross-line drone passes through center of eyepiece dividing plate.
 - c. Prism degree and value of basal angle of prism lens are read on the eyepiece dividing plate (Fig. 17).

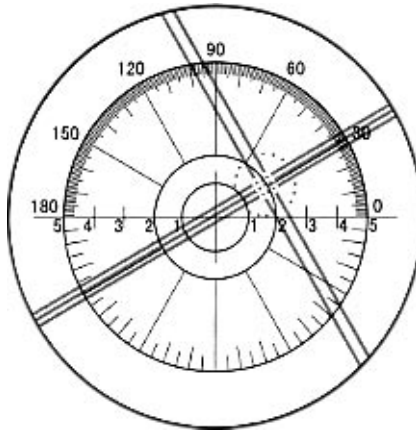

Fig. 17 (2Δ basal angle 30°)

*(2) In the range of 5 ~ 20 degrees of prism, prism compensator should be used.

- a. Turn diopter measuring hand-wheel to obtain distinct focus of drone.
- b. Turn adjusting knob of prism compensator so that drone is adjusted to a proper position of eyepiece visual field.

Matters Needing Attention

If drone is not in eyepiece visual field, turn angle of prism compensator to 0° or 90° , and turn adjusting knob of prism compensator to the left or right to make measurement easy.

- c. Turn diopter measuring hand-wheel to obtain clearest focus of drone.
- d. Values of prism degree are read on eyepiece dividing plate and prism compensator respectively, and the sum of both values is prism degree of this prism lens (Figs. 18 and 19).
- e. Basal angle of this prism lens is read on prism compensator (Fig. 19).

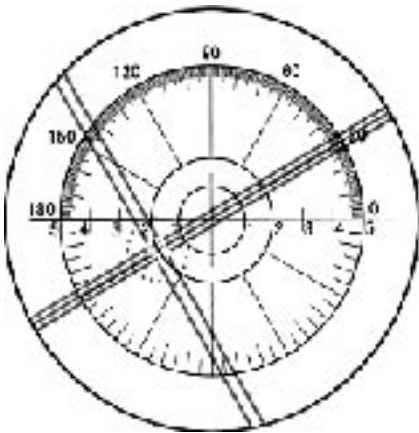

Fig. 18

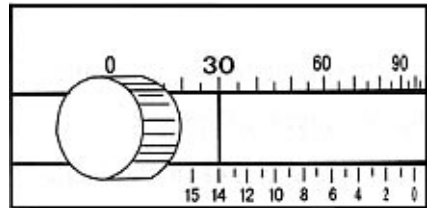

Fig. 19

Important Matters

* If value of prism degree is to be read from left side of reticle 0, 180° shall be added to that of basal angle of the prism lens.

It can be known from Fig. 18 and Fig. 19 that measured data of this prism lens are: prism degree 16Δ and basal angle 210° .

5.3 Calibration of Lens

5.3.1 Calibration of Spherical Lens

- (1) Turn diopter measuring hand wheel to obtain clearest focus of drone.
- (2) Lightly move lens so that drone is at center of eyepiece visual field.
- (3) Make 3-dot mark using dot-making mechanism.

5.3.2 Calibration of Cylindrical Lens

- (1) Turn astigmatism turning hand-wheel to show required angle on the liquid crystal display screen.
- (2) Turn diopter measuring hand wheel to obtain distinct focus of round dot drone when SPH (spherical degree) is a big value.
- (3) Turn lens so that 3 long green lines of round dot drone and cross-line drone are parallel.
- (4) Lightly move lens so that drone is at center of eyepiece visual field.
- (5) Make 3-dot mark using dot making mechanism.

5.3.3 Calibration of Prism Lens

- (1) Turn astigmatism turing hand-wheel to show required angle on the liquid crystal display screen.
- (2) Turn diopter measuring hand wheel to obtain distinct focus of drone.
- (3) Move lens or use prism compensator so that the middle one of 3 long green lines of cross-line drone passes through center of eyepiece visual field.
- (4) Make 3-dot mark using dot making mechanism.

5.3.4 Calibration of Optic Center of Assembled Two Lens

Put spectacles on the device. Choose any one of lens, and turn diopter measuring hand wheel to enable focus of drone to be clearest and at center of eyepiece visual field. Make central print-mark on this lens using dot making mechanism. Repeat the operation to make central print mark on another lens. By the use of vernier caliper, measure space between central print marks of two lenses.

5.4 Function of Automatic Dormancy

This device stops working for some 3 minutes. The auto-stop function: The lamp at this time is not lighted, and device comes into a State of low consumption dormancy. To resume measurement, press any measuring key, or turn diopter measuring hand-wheel.

Prompt

When the device is in the state of automatic dormancy, the measured data will not be limited.

5.5 Setting Grades of Measurement

Measuring grades of this device involve 4 grades: 0.01D, 0.06D, 0.12D and 0.25D. By pressing adjusting key ADJ first, and then pressing measurement switching key +/-, one can see these 4 grades of measurement (0.01D, 0.06D, 0.12D and 0.25D) are switched in circulation. Stop to press measurement switching key +/-, and press adjusting key ADJ, and it is possible to select the required grade of measurement (Fig.20).



Fig. 20

6 Maintenance of Device

- (1) The device has undergone precise adjustment before delivered from manufacturing plant. Please do not disassemble it at random to ensure precision of the measurement.
- (2) The device shall be used in an indoor well-conditioned dry place to prevent optic elements from mildewing after affected with damp.
- (3) After using the device, keep it in a clean state and cover it with dustproof shield.
- (4) The device shall be prevented from strong vibration or impact to avoid damage and looseness of each component, thus to ensure precision of measurement
- (5) Always keep the device clean and do not touch surface of this optic part. If dust or besmirch is found on it, be sure to clean it with absorbent cotton dipped with mixed solution of ethanol and aether.

Matters Needing Attention

For cleaning the device, do not use organic solution such as paint thinner, otherwise surface of the device will be damaged.

7 Troubleshooting

No.	Failure	Reasons of Failure	Solutions
1	Liquid crystal screen is not lighted	Lamp is not lighted	Switch on power supply
2	When ocular visibility is adjusted, ocular dividing plate cannot be seen clearly	Degree of testee's eyes is too deep or he (she) has astigmatism	Wear spectacles
3	Drone can not be seen	Lamp is lighted	Switch on power supply
		Dustproof shield is not removed	Take off dustproof shield
4	Drone is not clearly seen	Dust on optic lens	Clean it with absorbent cottondipped with cleaning solution
5	Excursion of drone center	Lock screw is loosened	Take off measurement bearing seat, and adjust and tighten 3 lock screws
6	Shifting of dot-making mechanism	Limit screw is loosened	Adjust and tighten limit screw
		Connecting screw is loosened	Adjust and tighten connecting screw